

HC200 Conveyors

Installation & Maintenance Instructions



Contents

Warnings	2
Tools	3
Installation	4
Maintenance	8
Recommended Spare Parts	14
Troubleshooting	17
Exploded Views	16
Warranty Information	28
Service Record	29



QC Conveyors
4057 Clough Woods Dr.
Batavia, OH 45103 USA

+1 (513) 753-6000
qcconveyors.com

Warnings



When used improperly, conveyor rollers can pinch or maim



Lock out power before servicing conveyor

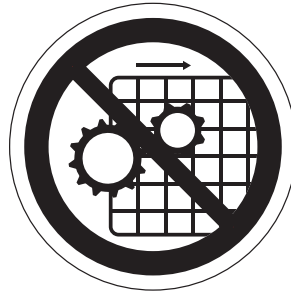

Do not use with guards removed



Read this manual before operating



Any modifications will nullify BISSC Certification

DANGER



WARNING

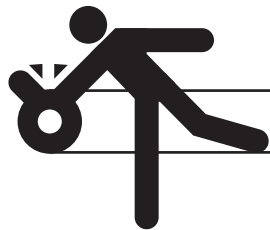

WARNING



WARNING



Tools

► Required Tools

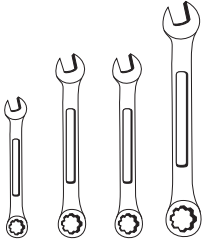

Metric Wrenches (two 10mm's, 6mm, 13mm)

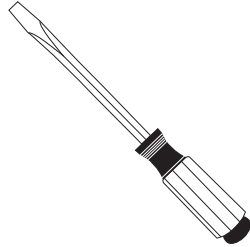

Flat Head Screwdriver



10" Adjustable Wrench



Bubble level

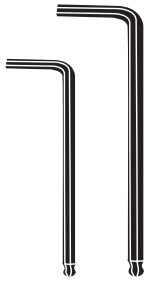

Metric allen wrench set (3mm & 2.5mm)

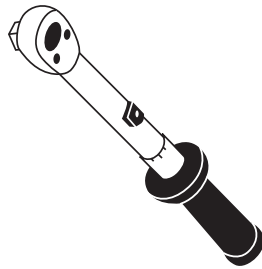

Torque wrench with flat head socket (Range 2- 8 Nm)

► Optional Tools

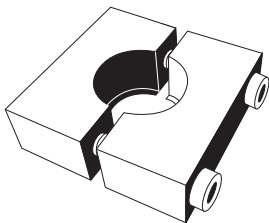

QC Conveyors bearing removal tool (part# 1A0077A)

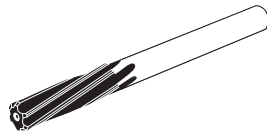

Ream \varnothing .251 - \varnothing .253



Screw Gun

Installation

► Check Your Shipment

Before opening the shipment, visually inspect the outside of the crate/box for shipping damage. Carefully unpack the crate/box, inspecting for component damage which may have occurred inside the packing materials. Contact the carrier and QC Conveyors regarding any damage that may have occurred during shipment. Check the contents of your shipment against the supplied packing slip and inform QC Conveyors of any discrepancies.

► General Sequence of Installation

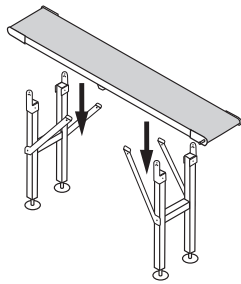

1 Mount conveyor to stands or compatible mounting brackets.

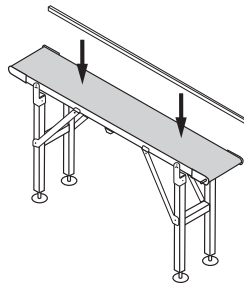

2 Attach sides or guides, ensure underside idlers are in place and adjust as needed.

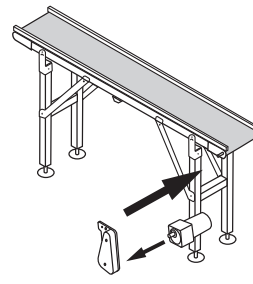

3 Install drive motor and mounting package. (Where applicable)

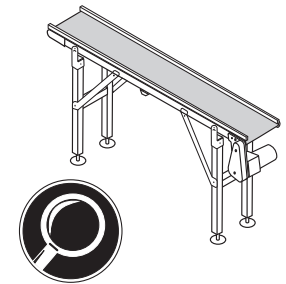

4 Lag conveyor to floor/ Engage caster locks, ensure all pins are in place and inspect conveyor.

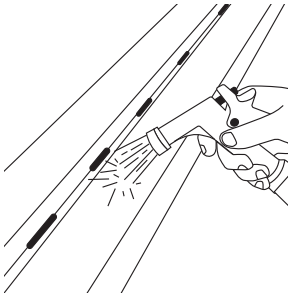

5 HC200 conveyors should be cleaned before use. (Review recommended instructions in the cleaning section of this manual on page 6)

► Assistance

If you need assistance, please contact QC Conveyors customer service department Monday through Friday, 8am-5pm EST at (513) 753-6000. In addition, your local distributor has been trained at the factory and can provide support in many ways. You can also visit our website - qcconveyors.com - for additional information and technical documents.

Stand / Mount Installation

► Stainless Steel Stands with Leveling Feet

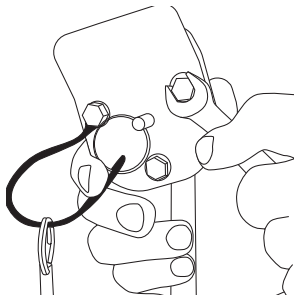

1 Loosen (do not remove) screws on stand mounting clamps.

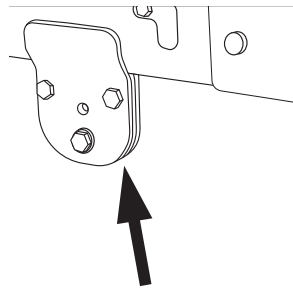

2 Place mounting clamps with three screws as close to ends of conveyor possible. (Within two feet of conveyors end)

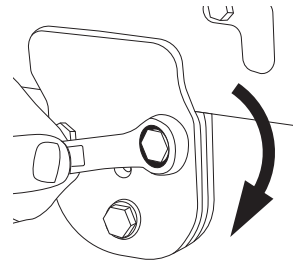

3 Tighten screws.

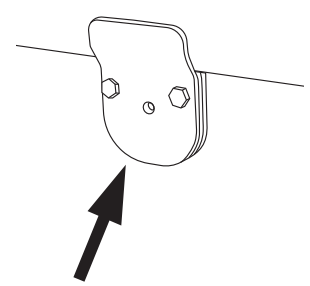

4 Place mounting clamps with two screws near middle of conveyor frame.

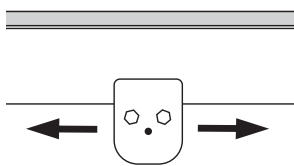

5 Slide center mounted clamps into position where angle braces can reach them (aprx: 9.75in from outside clamp).

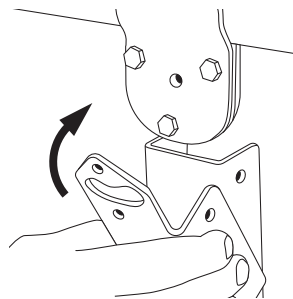

6 Flip up brackets to meet end clamps.

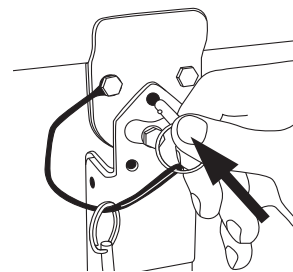

7 Insert pins through upper holes in flip brackets and through clamps.

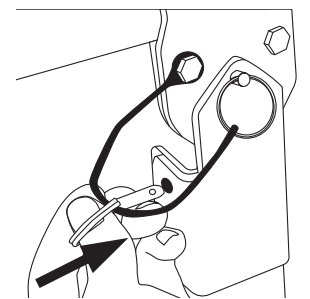

8 Insert pins through side hole in flip brackets and through stand legs to lock bracket in place.

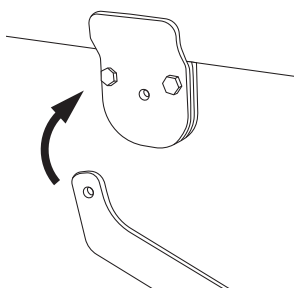

9 Swing angle brackets up to meet inner clamps on frame.

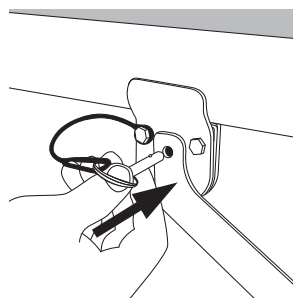

10 Insert pin through angle bracket and into mounting clamp.

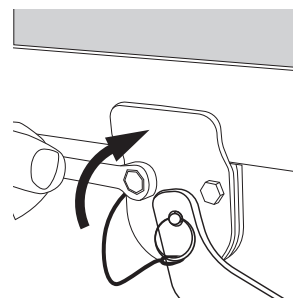

11 Tighten screws on mounting clamp.

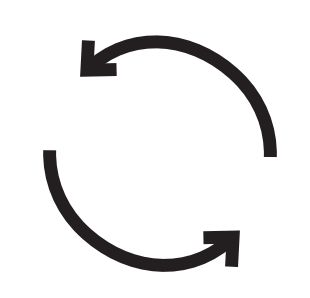

12 Repeat steps at opposite end of conveyor.

Outside edge of stand mounts should be placed 12" from end of conveyor, unless application needs dictate otherwise.

► Adjusting Leveling Feet

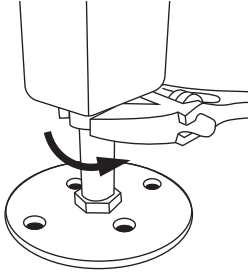

1 Use a large adjustable wrench to loosen hex nut.

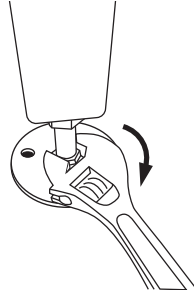

2 Rotate the welded nut until desired height is achieved.

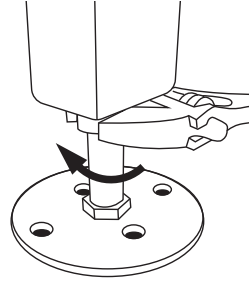

3 Retighten hex nut to secure it in position.

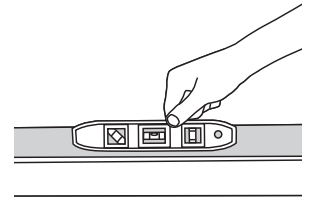

4 Check with bubble level along length of conveyor to ensure conveyor is level.

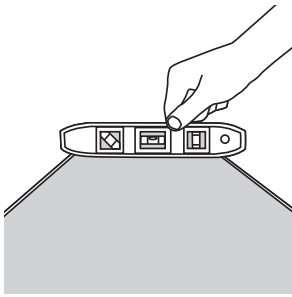

5 Check with bubble level along width of conveyor to ensure conveyor is level.

⚠ Injury is possible if stands are not lagged to floor, cross ties are not used, or angle braces are not present. Never place a conveyor in operation until all proper mounts are installed and secured.

► Mounts

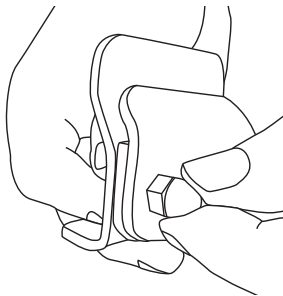

1 Loosen screws in mount assembly. (Do not remove).

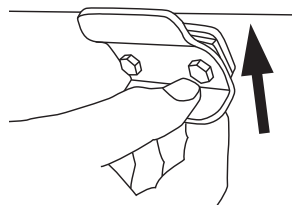

2 Place mounts along frame, within two feet of conveyor ends.

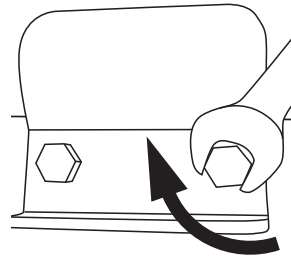

3 Retighten screws to secure it in position.

Outside edge of stand mounts should be placed 12" from end of conveyor, unless application needs dictate otherwise.

Side / Guide Installation

► Installing Fixed Side Rails

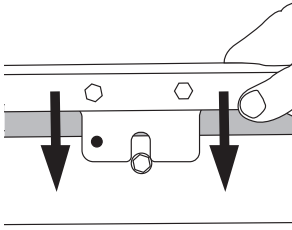

1 Slide side rail onto spacers in frame.

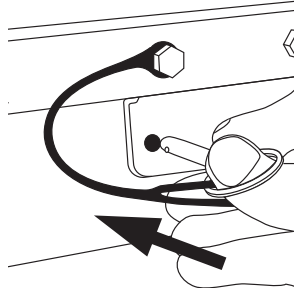

2 Insert pins through holes at each end of side, through brackets and into frame.

Finalizing Installation

► Checking Belt for Neutral

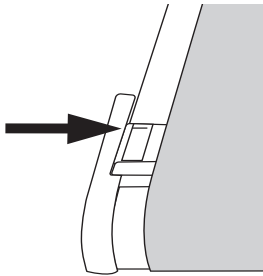

1 Check neutral mark in between belt and bearing housing, at tail end of conveyor.

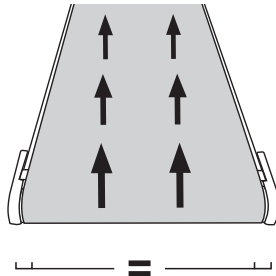

2 Belt should be run, and allowed to make several revolutions to check for proper tracking

Maintenance

Care and Cleaning

► General Recommended Cleaning Steps



1 Lock out power per your facility's procedure and remove belt, tail end and drive end. (Refer to belt removal section of this manual)

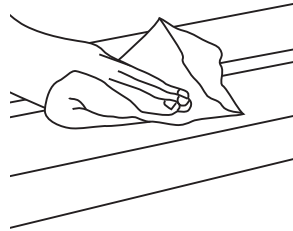

2 Clear conveyor of any large particles. (Wipe with cloth or scrape with plastic scraper)

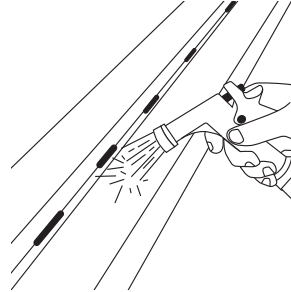

3 Pre-rinse conveyor.

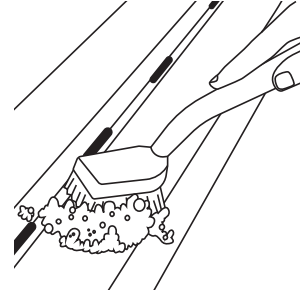

4 Scrub conveyor with your facility's specified cleaning solution.

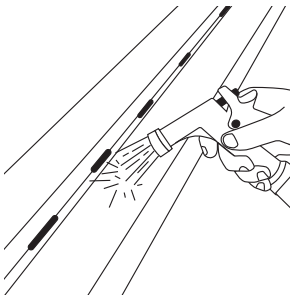

5 Rinse off conveyor.

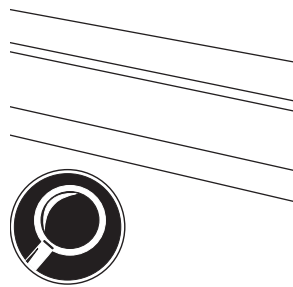

6 Check to ensure conveyor is free of dirt. (Repeat steps 3-5 if needed)

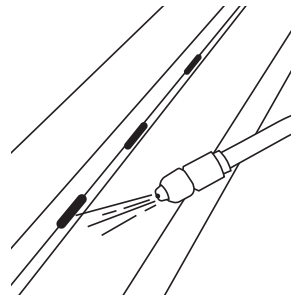

7 Apply sanitizer per your facility's specifications.

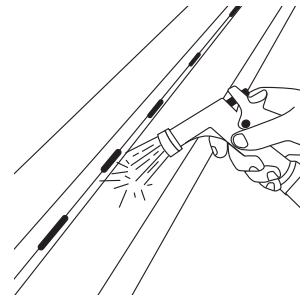

8 If sanitizer is not allowed to dry, rinse off conveyor.

- > Re-install Tail End and Drive End using steps on the following page.
- > Re-install belt using steps in the belt change section of this manual.

* Due to the diversity of materials and applications, the information given on this page represents only a general guideline. The cleaning process should be individually optimized to follow your facility's guidelines and standards. QC Conveyors recommends following chemical manufacturers specifications, limitations and recommendations in regards to dry time, materials the solution can be applied to and method of application.

► Tail End Removal For Cleaning

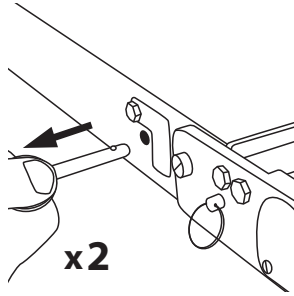

1 Remove pins holding tail assembly to frame.

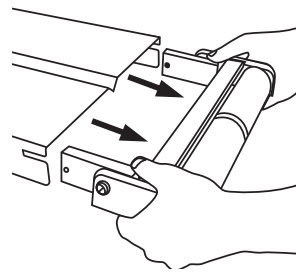

2 Slide tail assembly out of frame.

► Tail End Replacement After Cleaning

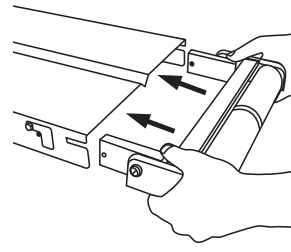

1 Slide tail pulley assembly into frame.

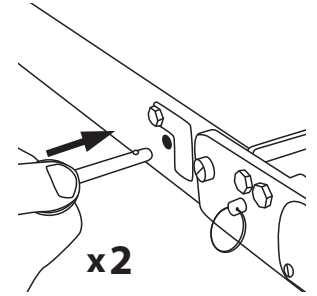

2 Re-insert both pins holding tail pulley to frame.

► Drive End Removal For Cleaning

> Remove drive package

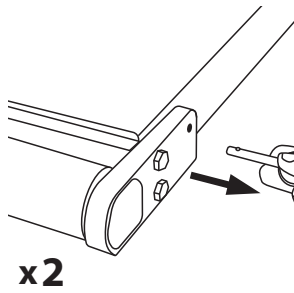

1 Remove pin from bearing housing opposite side of drive shaft.

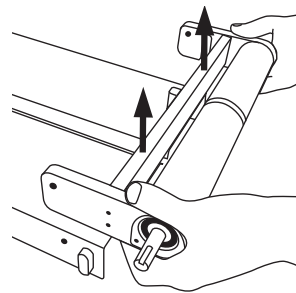

2 Slide drive pulley assembly up and out of frame. (Drive Package does NOT need to be removed)

► Drive End Replacement After Cleaning

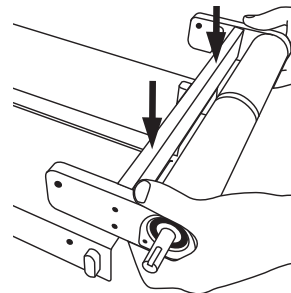

1 Slide drive pulley assembly onto frame.

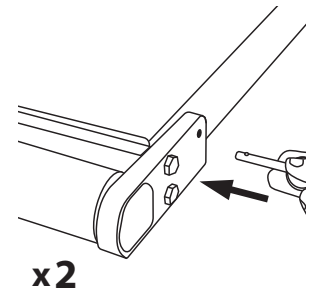

2 Insert pin through bearing housing opposite drive mounting package.

- > Re-install drive package after cleaning is complete.
- > Re-install belt after cleaning is completed. (Follow steps in Belt Change section of this manual)
- > Belt may need to be tracked or tensioned. (Follow steps in Belt Tracking and Belt Tensioning sections of this manual)

Belt Tracking

> For best results, make adjustments to only one side.

► Belt Tracking at Tail End

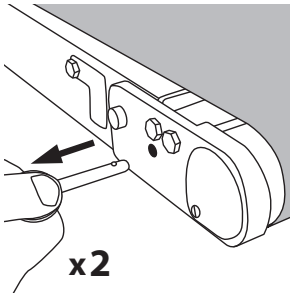

1 Pull both pins in tail assembly.

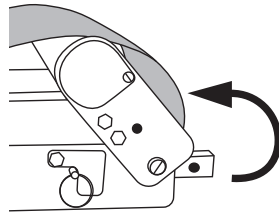

2 Flip tail assembly into disengaged position.

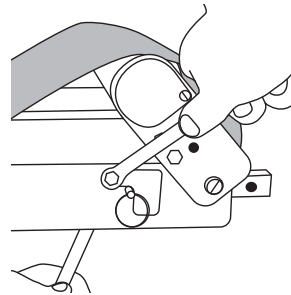

3 While holding a 10mm wrench on nut under frame, loosen hex head screw on tensioning window. (Do not remove)

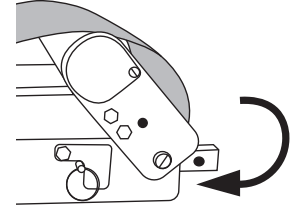

4 Lower tail assembly back into engaged position.

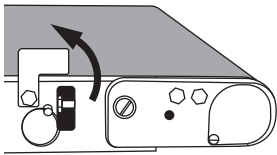

5 Rotate tensioning window into open position.

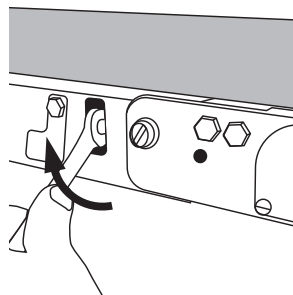

6 Rotate tensioning screw to make tracking adjustments. (Moving tail out will move belt away from bearing plate on that side)

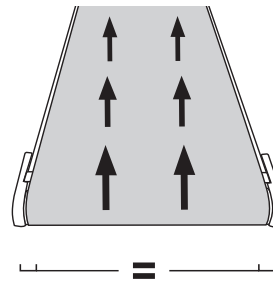

7 Run conveyor and let it make several revolutions to ensure belt is centered on frame and pulley.

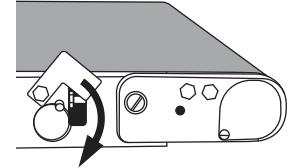

8 Rotate tensioning window back into closed position.

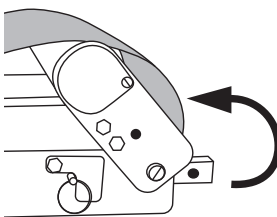

9 Flip tail assembly into disengaged position.

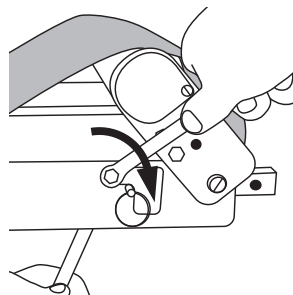

10 While holding a 10mm wrench on nut under frame, tighten hex head screw on tensioning window.

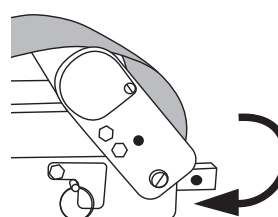

11 Lower tail assembly back into engaged position.

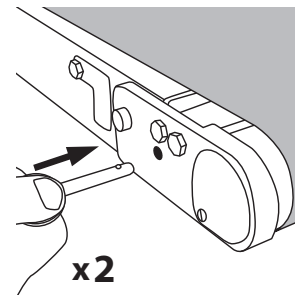

12 Re-insert both pins into tail assembly.

Belt Change

► Removal of Existing Belt

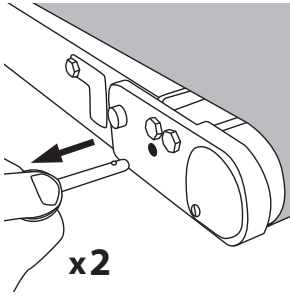

1 Pull both pins from bearing housing in tail assembly. (One in each side)

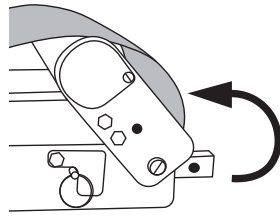

2 Flip tail assembly into disengaged position.

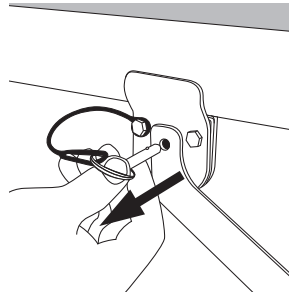

3 Remove pins in stand bracket at angle brace on opposite side of drive.

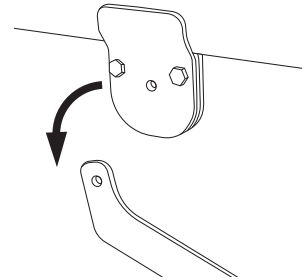

4 Flip angle brace down.

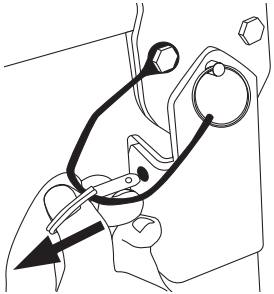

5 Pull pins out from sides of flip-down stand brackets on opposite side of drive.

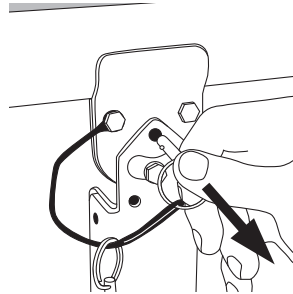

6 Pull pins from stand brackets at legs.

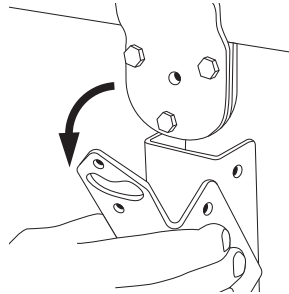

7 flip stand bracket down.

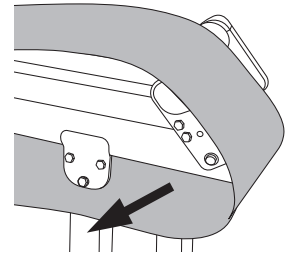

8 Slide belt off of conveyor.

► Installation of New Belt

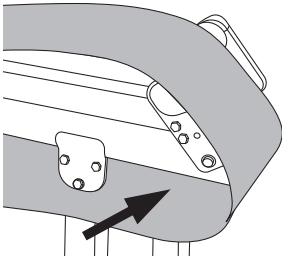

1 Slide new belt onto conveyor. (Ensure belt is clear of all idler pulleys, screws and is within frame)

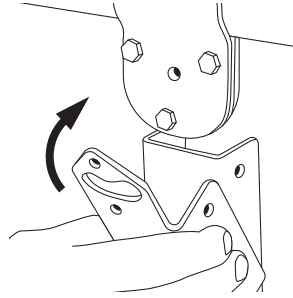

2 Flip stand brackets back up to engage brackets on frame.

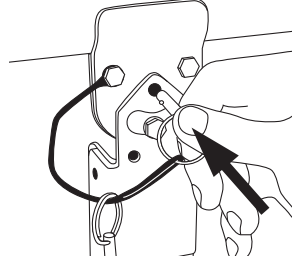

3 Insert pins through flip-up stand brackets and into brackets on frame.

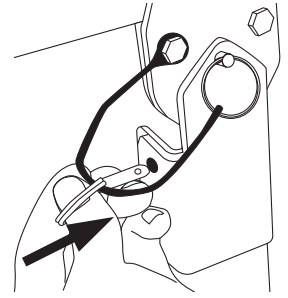

4 Insert pins into side of stand bracket on legs.

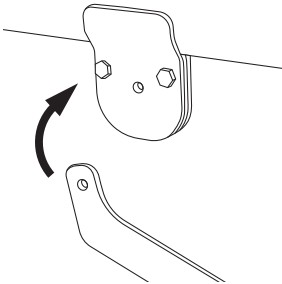

5 Rotate angle brace back into place to engage bracket on frame.

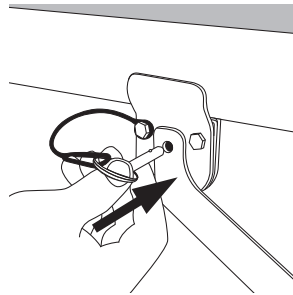

6 Re-insert pins through angle braces and into brackets on frame using upper hole.

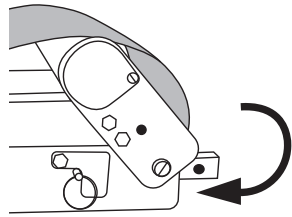

7 Flip tail pulley back into the engaged position. (Ensure v-guide on belt is seated in v-guide in frame and pulleys)

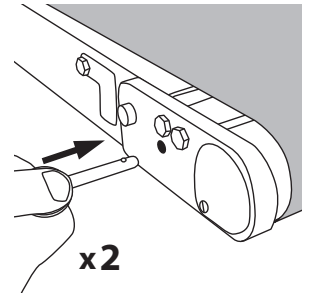

8 Re-insert pins through bearing housings in tail end.

Belt Tensioning

► Belt Tension at Tail End

Check neutral position (page 7) before adding or removing tension.

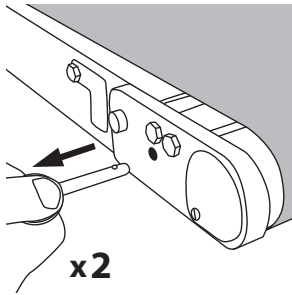

1 Remove pins from both bearing housings at tail end.

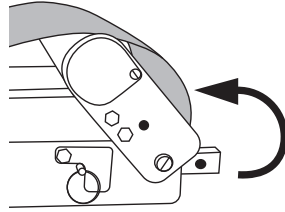

2 Lift tail into disengaged position.

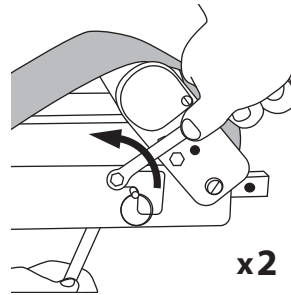

3 While holding a 10mm wrench on nut under frame, loosen hex head screw holding tensioning windows on both sides. (Do not remove screws)

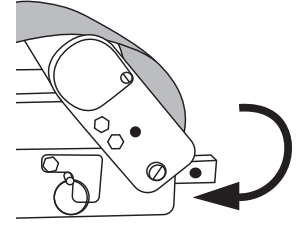

4 Flip tail back down into the engaged position.

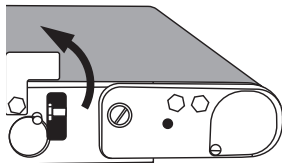

x2

5 Rotate tensioning windows on both sides up into open position.

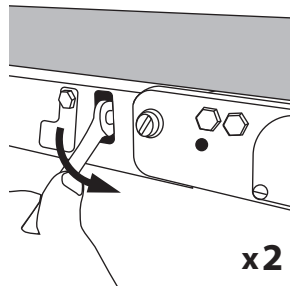

x2

6 Add or remove tension by adjusting tensioning screws on both sides. (Ensure both screws are adjusted the same amount)

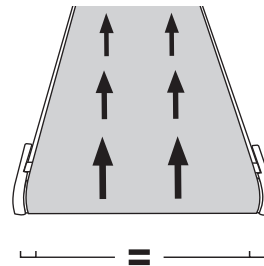

7 Run conveyor to ensure belt tracks properly. (If tracking is needed, refer to Belt Tracking section of this manual)

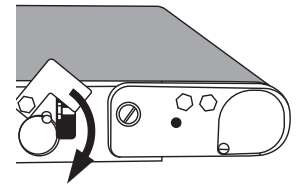

x2

8 Rotate both tensioning windows down into closed position.

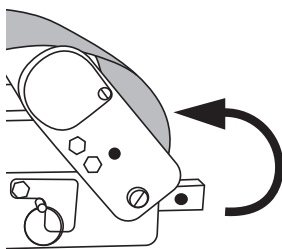

9 Lift tail into disengaged position.

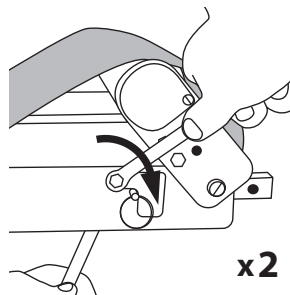

x2

10 While holding a 10mm wrench on nut under frame, tighten hex head screws holding tensioning windows on both sides.

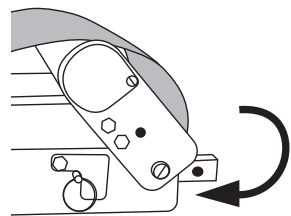

11 Flip tail back down into the engaged position.

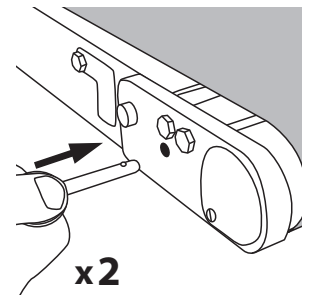

x2

12 Re-insert both pins into tail assembly.

If additional belt tension is needed after following these steps, it is recommended that a new belt be installed.

Bearing & Pulley Replacement

► Drive Pulley & Bearing Assembly Replacement

- > It is recommended that the belt be removed. (Follow steps for correct belt in belt change section of this manual)
- > Drive package will need to be removed.

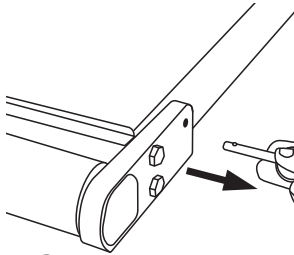

x2

1 Remove pin from bearing housing opposite side of drive shaft.

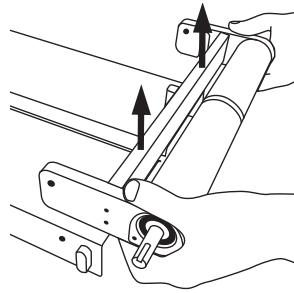

2 Slide drive pulley assembly up and out of frame.

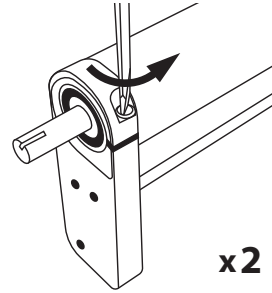

x2

3 Loosen clamping screws on both bearing blocks.

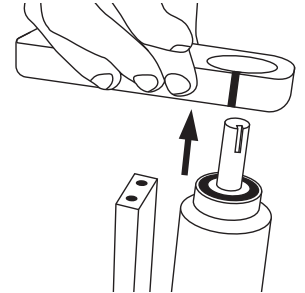

4 Remove bearing block from pulley/bearing assembly.

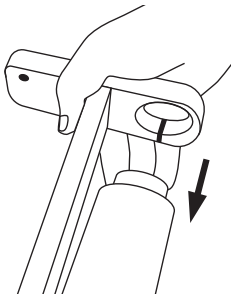

5 Remove old pulley/bearing assembly from opposite bearing block.

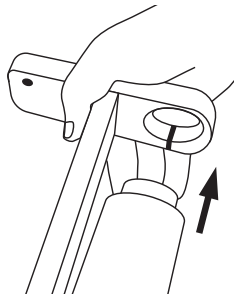

6 Install new pulley/bearing assembly into bearing block.



7 Install bearing block onto new pulley/bearing assembly.

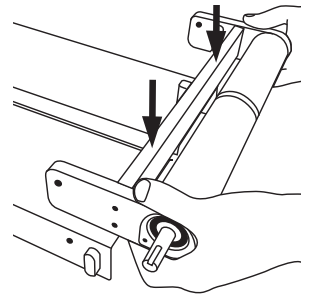

8 Slide drive pulley assembly onto frame.

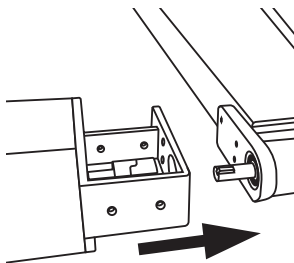

9 Re-install drive package.

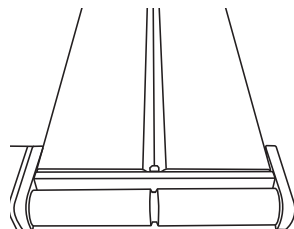

10 Ensure v-guide in pulley is aligned with v-guide in frame.

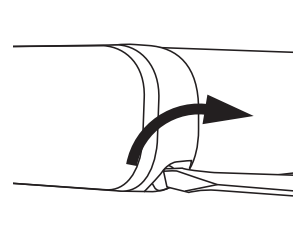

x2

11 Tighten clamping screws in both bearing blocks. (2.5 Nm - 22 in/lbs.)

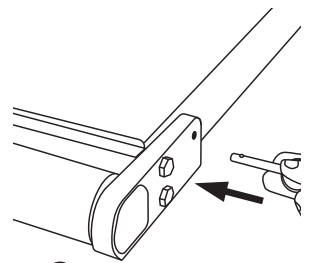

x2

12 Insert pin through bearing housing opposite drive mounting package.

- > Re-install belt. (Follow steps in belt change section of this manual)
- > If tensioning adjustment is needed, refer to belt tensioning section of this manual.
If tracking adjustment is needed, refer to belt tracking section of this manual.

► Tail Pulley & Bearing Assembly Replacement

> It is recommended that the belt be removed. (Follow steps for correct belt in belt change section of this manual)

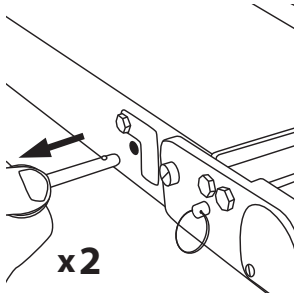

1 Remove pins holding tail assembly to frame.

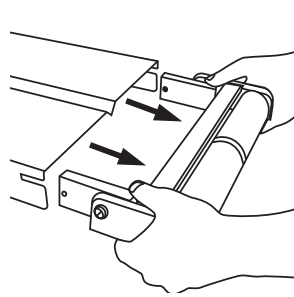

2 Slide tail assembly out of frame.

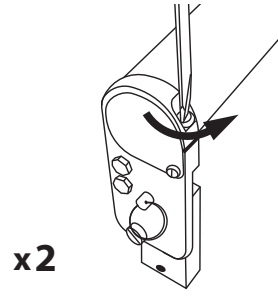

3 Loosen clamping screws in both bearing housings. (Do not remove)

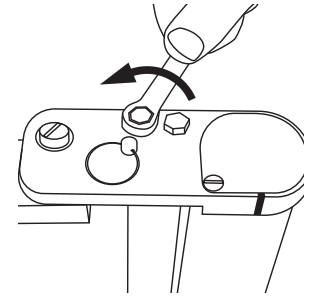

4 Loosen both hex head screws in bearing housing.

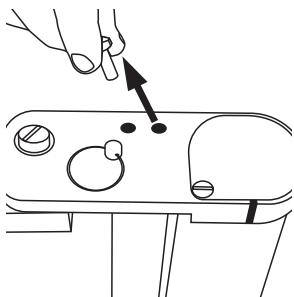

5 Remove both hex head screws.

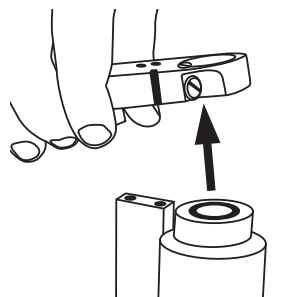

6 Remove bearing housing from tail pulley assembly.

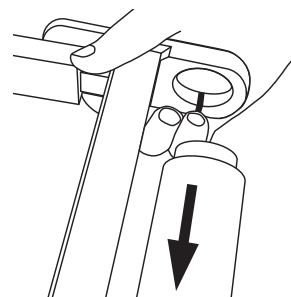

7 Slide old pulley / bearing assembly out of opposite bearing housing.

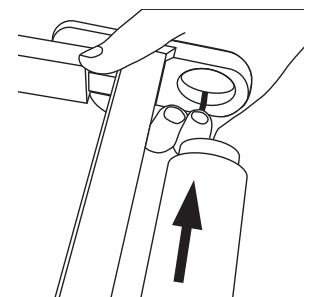

8 Install new pulley / bearing assembly into bearing housing.

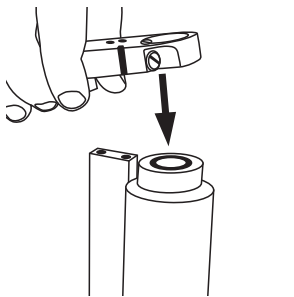

9 Install bearing housing to free side of tail pulley bearing assembly.

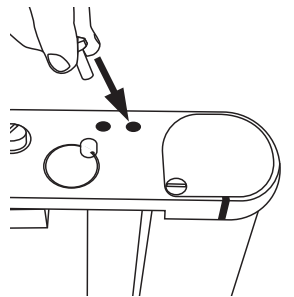

10 Apply loctite to two hex head screws and insert them through bearing housing and into cross block.

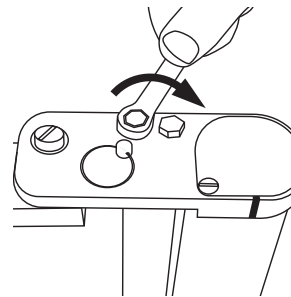

11 Tighten hex head screws.

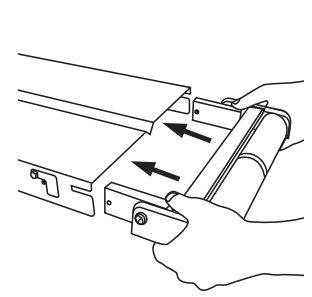

12 Slide tail pulley assembly into frame.

► Tail Pulley & Bearing Assembly Replacement (continued)

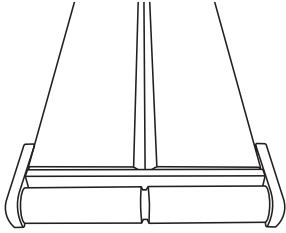

13 Ensure v-guide in frame is aligned with v-guide in pulley.

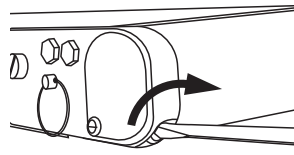

x2

14 Tighten clamping screws in both bearing housings. (2.5 Nm - 22 in/lbs.)

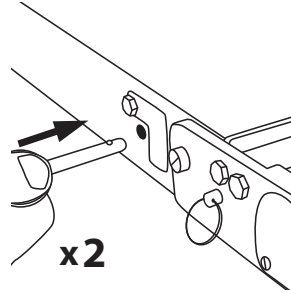

x2

15 Re-insert both pins holding tail pulley to frame.

- > Re-install belt. (Follow steps in belt change section of this manual)
- > If tensioning adjustment is needed, refer to belt tensioning section of this manual.
If tracking adjustment is needed, refer to belt tracking section of this manual.

Recommended Spare Parts

► Parts List

Part #	Description
HEA-WW-LLL-XVX	V-Guided Belt
310112-264421-LAYRD	Nylon Lanyard
HEA-2016-00	Removable Pin
HEA-2009-00	Bearing Cover
PHSMS-M04X070X006	Bearing Cover Screw
HEA-2503-WW	Drive Pulley/Bearing Assembly
HEA-2501-WW	Tail Pulley/Bearing Assembly
HEA-2013-00	Tension Window Cover
HHCS-M06X100X010-SS	Tension Window Cover Screw
HEA-2014-00	Tension Window Cover Acorn Nut

- > Use the two digit width of the conveyor for "WW".
Use the three digit length of the conveyor for "LLL".
- > To order parts, please visit QCconveyors.com/serial or call us at +1 (513) 753-6000.

Troubleshooting

Symptom	Possible Cause	Corrective Action
Belt is slipping or stops under load	Demand is more than the conveyor is rated for	Verify conveyor capacity
	Lubrication between drive pulley and belt	Clean bottom of belt and drive pulley
Belt does not move without load	Timing belt under drive guard is not connected or has stretched / drive couplings are not connected	Verify engagement of timing belt or coupling under drive guard
	Tail pulley assembly not tensioned properly	Refer to section on tensioning the belt
Belt will not track at tail end	Irregular product loading or belt wear	Refer to Belt Tracking section of this manual
	Improper tension	Refer to Belt Tensioning section of this manual
Belt is brittle, delaminating or is discolored	Belt is being attacked by chemicals or excessive heat	Contact factory to discuss belt application
	Belt life has expired	Replace belt
	Urethane belts can discolor when exposed to UV light	No corrective action
Motor is hot	Motor can run with a skin temperature of 221°F	No corrective action
	Motor is not protected with overload protection and is drawing too much current	Install overload protection on motor
Speed reducer is getting hot	Speed reducer can run with skin temperature of 225°F	No corrective action
Speed reducer is leaking oil	Speed reducer's life has expired	Replace speed reducer
	Installation was performed incorrectly and input seal was damaged	Replace speed reducer
Bearing noise	Bearings are damaged or failing	Refer to Bearing & Pulley Replacement section of this manual
Belt is traveling reverse of desired direction	Motor or speed reducer not wired properly	Check wiring and correct per wiring instructions
Conveyor belt has prematurely worn out	Correct belt not selected for application	Contact factory to discuss belt application

If you are unable to remedy the problem with these corrective actions, please contact QC Conveyors Customer Service at +1 (513) 753-6000. Failure to correct the problem may lead to abnormal use of the conveyor, thereby voiding the warranty.

Exploded Views / BoM's

► HC200 Conveyor

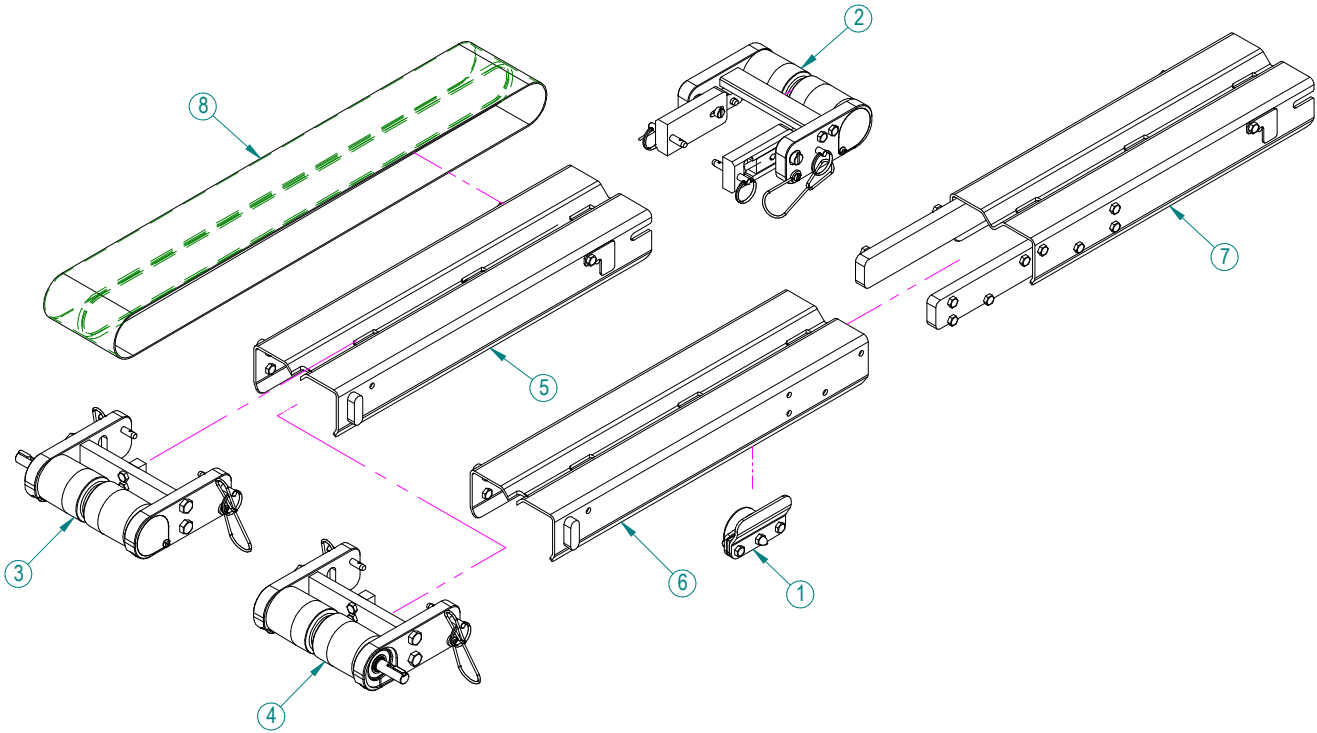

#	Description	Part #
1	ASSY IDLER	HE1-2505-00
2	ASSY TAIL FLIP UP	HEA-2500-WW
3	ASSY DRIVER LEFT HAND OUTPUT	HEA-2502-WW
4	ASSY DRIVER RIGHT HAND OUTPUT	HEA-2504-WW
5	ASSY SLIDER BED FRAME	HEA-2511-WW-LLL.LL
6	ASSY SLIDER BED FRAME DRIVE END	HEA-2521-WW-LLL.LL
7	ASSY SLIDER BED FRAME TAIL END	HEA-2522-WW-LLL.LL
8	BELT V-GUIDED	HEA-WW-LLL-XVX

► HC200 Conveyor With Side Rail Hardware

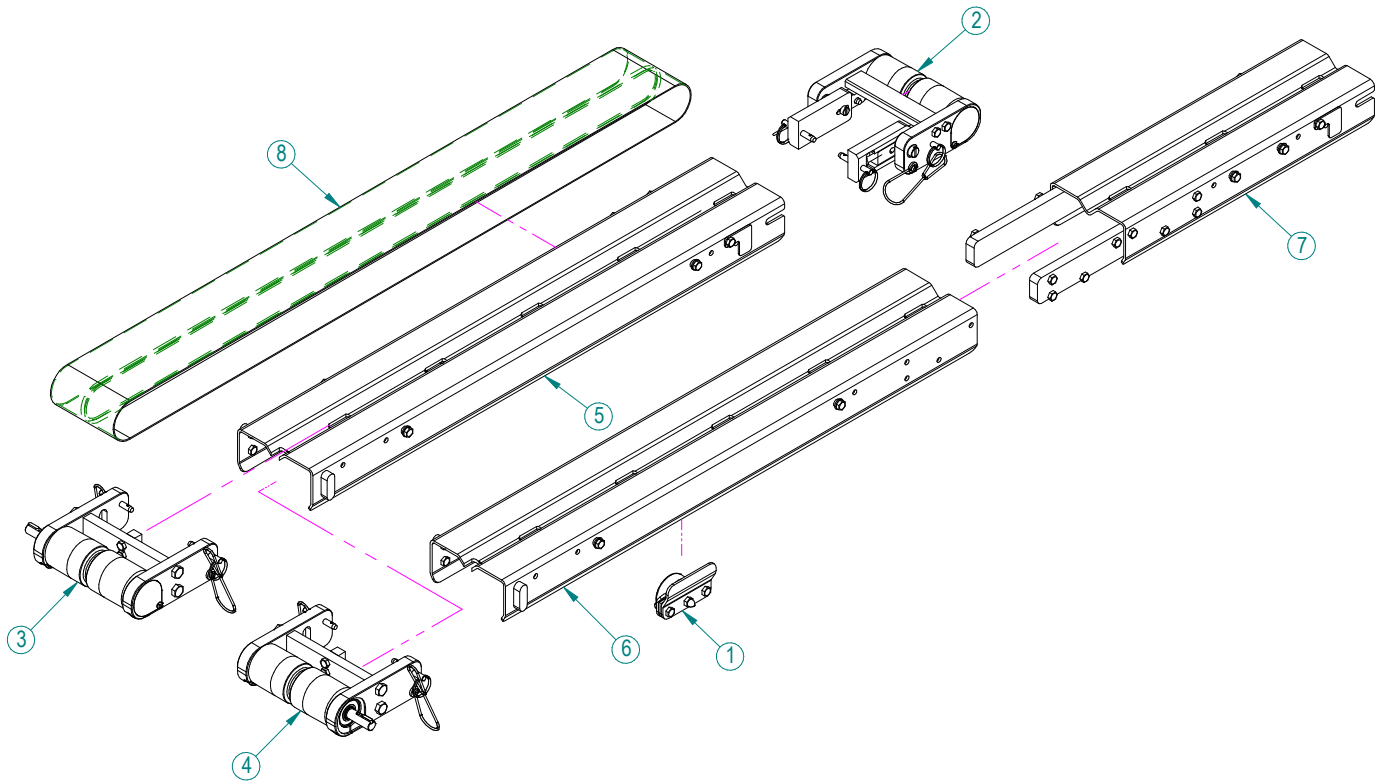

#	Description	Part #
1	ASSY IDLER	HE1-2505-00
2	ASSY TAIL FLIP UP	HEA-2500-WW
3	ASSY DRIVER LEFT HAND OUTPUT	HEA-2502-WW
4	ASSY DRIVER RIGHT HAND OUTPUT	HEA-2504-WW
5	ASSY SLIDER BED FRAME WITH RAIL HARDWARE	HEA-2530-WW-LLL.LL
6	ASSY SLIDER BED FRAME DRIVE END WITH RAIL HARDWARE	HEA-2531-WW-LLL.LL
7	ASSY SLIDER BED FRAME TAIL END WITH RAIL HARDWARE	HEA-2532-WW-LLL.LL
8	BELT V-GUIDED	HEA-WW-LLL-XVX

► Slider Bed Frame With and Without Side Rail Holes

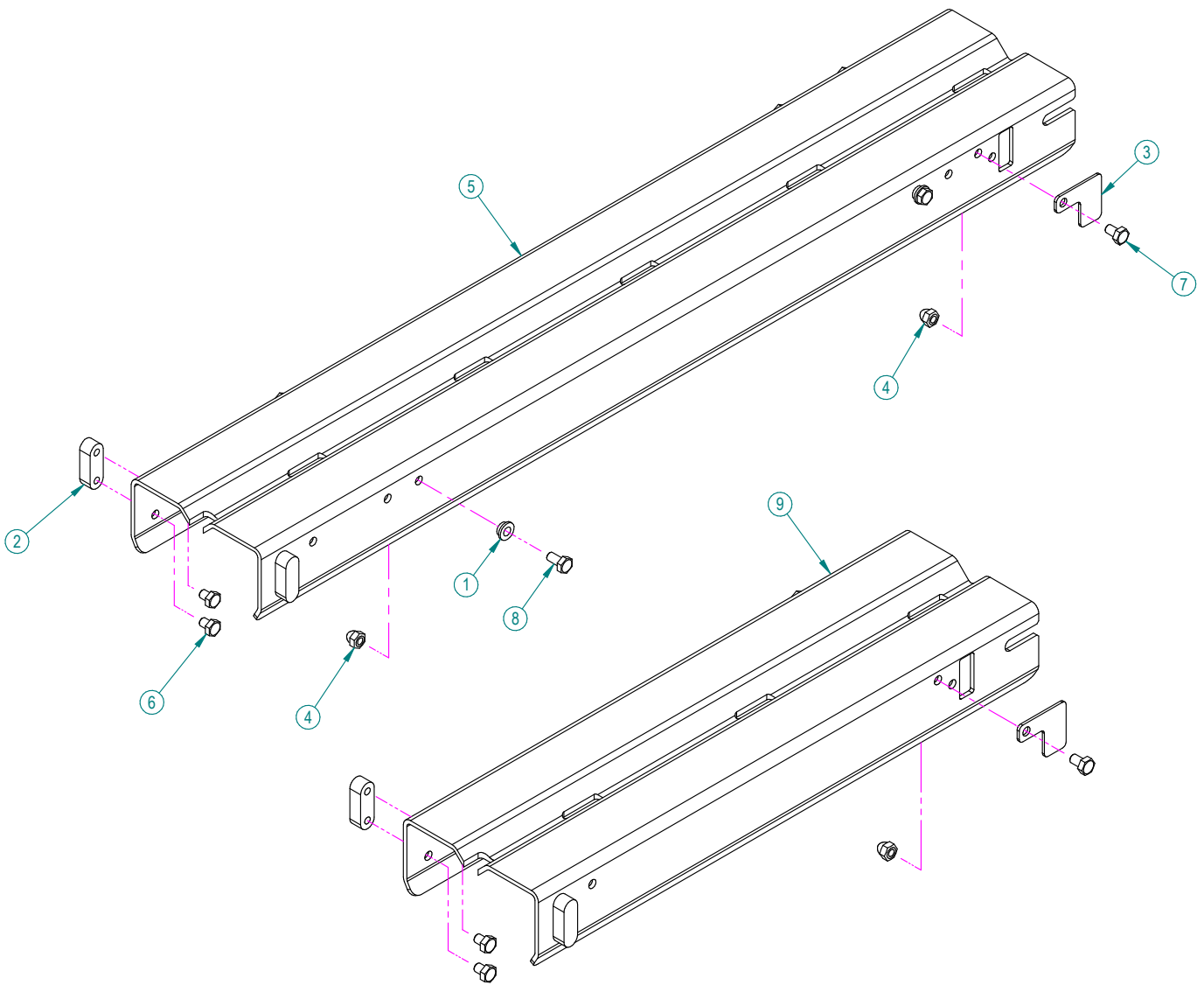

#	Description	Part #
1	FLANGED MOUNTING SPACER	HE1-2038-00
2	MOUNT DRIVE END	HEA-2001-00
3	COVER TENSION WINDOW	HEA-2013-00
4	ACORN NUT STAINLESS STEEL M6	HEA-2014-00
5	FRAME SLIDER BED DRIVE EXTENSION W/SIDE RAIL HOLES	HEA-2080-WW-LLL.LL
6	SCREW HEX HEAD CAP M6 X 1 X 8 SS	HHCS-M06X100X008-SS
7	SCREW HEX HEAD CAP M6 X 1 X 10 SS	HHCS-M06X100X010-SS
8	SCREW HEX HEAD CAP M6 X 1 X 12 SS	HHCS-M06X100X012-SS
9	SLIDER BED FRAME	HEA-2040-WW-LLL.LL

► Drive End Slider Bed Frame With and Without Side Rail Holes for Extended Frames

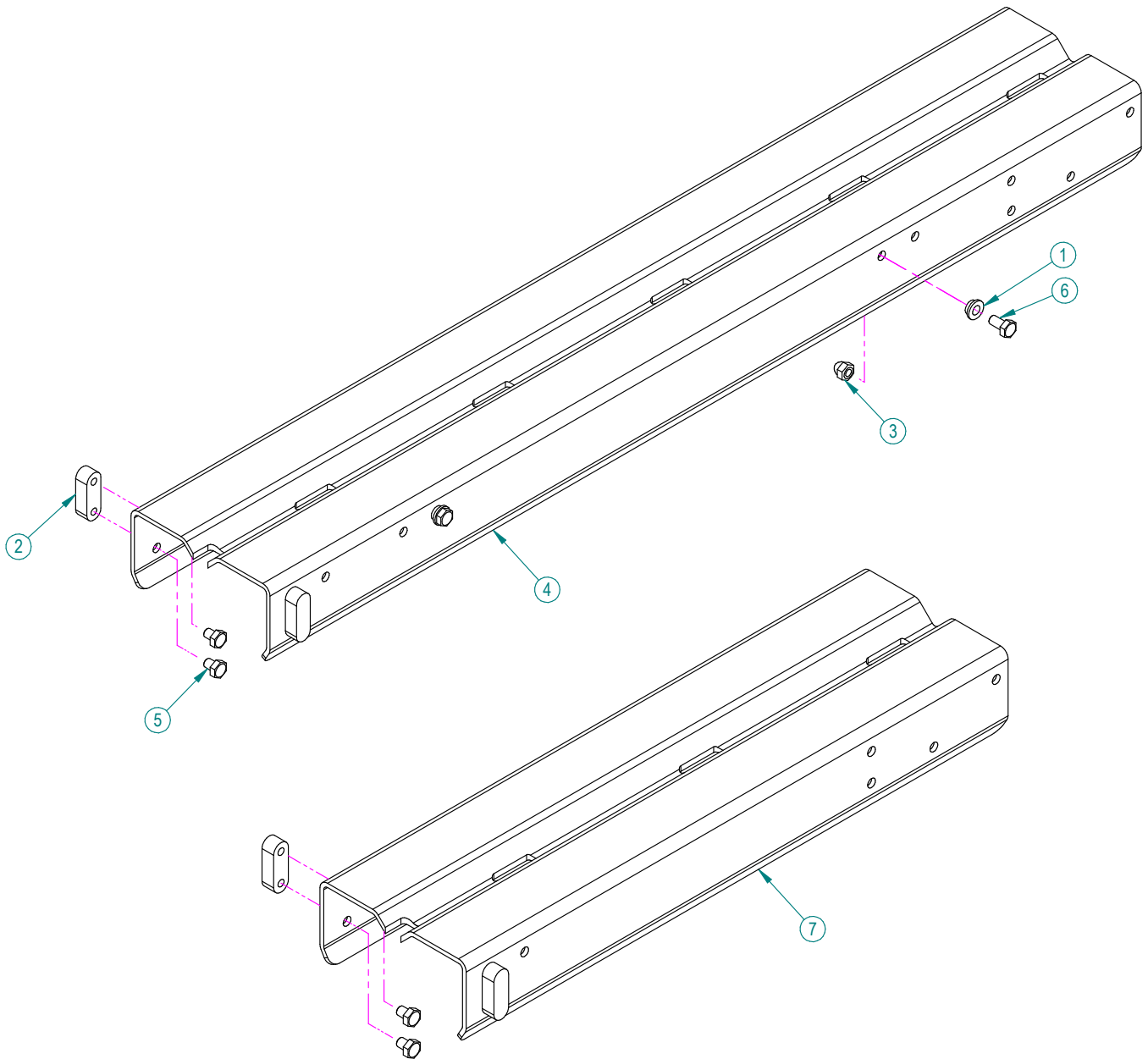

#	Description	Part #
1	FLANGED MOUNTING SPACER	HE1-2038-00
2	MOUNT DRIVE END	HEA-2001-00
3	ACORN NUT STAINLESS STEEL M6	HEA-2014-00
4	FRAME SLIDER BED DRIVE EXTENSION W/SIDE RAIL HOLES	HEA-2081-WW-LLL.LL
5	SCREW HEX HEAD CAP M6 X 1 X 8 SS	HHCS-M06X100X008-SS
6	SCREW HEX HEAD CAP M6 X 1 X 12 SS	HHCS-M06X100X012-SS
7	FRAME SLIDER BED DRIVE EXTENSION	HEA-2042-WW-LLL.LL

► Tail End Slider Bed Frame With and Without Side Rail Holes for Extended Frames

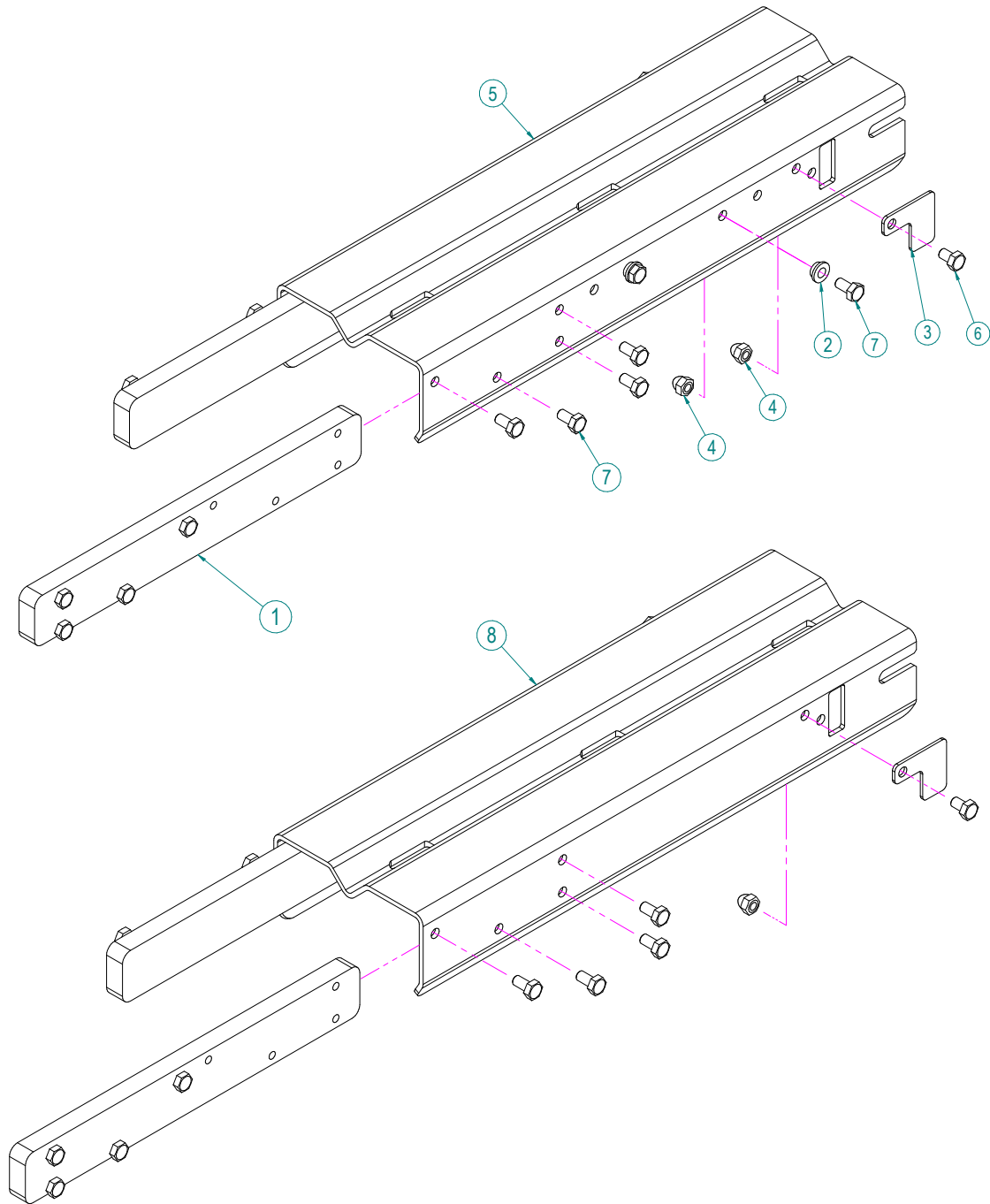

#	Description	Part #
1	TIE BAR EXTENDED FRAME	HE1-2027-00
2	FLANGED MOUNTING SPACER	HE1-2038-00
3	COVER TENSION WINDOW	HEA-2013-00
4	ACORN NUT STAINLESS STEEL M6	HEA-2014-00
5	FRAME SLIDER BED TAIL EXTENSION W/SIDE RAIL HOLES	HEA-2082-WW-LLL.LL
6	SCREW HEX HEAD CAP M6 X 1 X 10 SS	HHCS-M06X100X010-SS
7	SCREW HEX HEAD CAP M6 X 1 X 12 SS	HHCS-M06X100X012-SS
8	FRAME SLIDER BED TAIL EXTENSION W/SIDE RAIL HOLES	HEA-2042-WW-LLL.LL

► Left Hand Driver Output

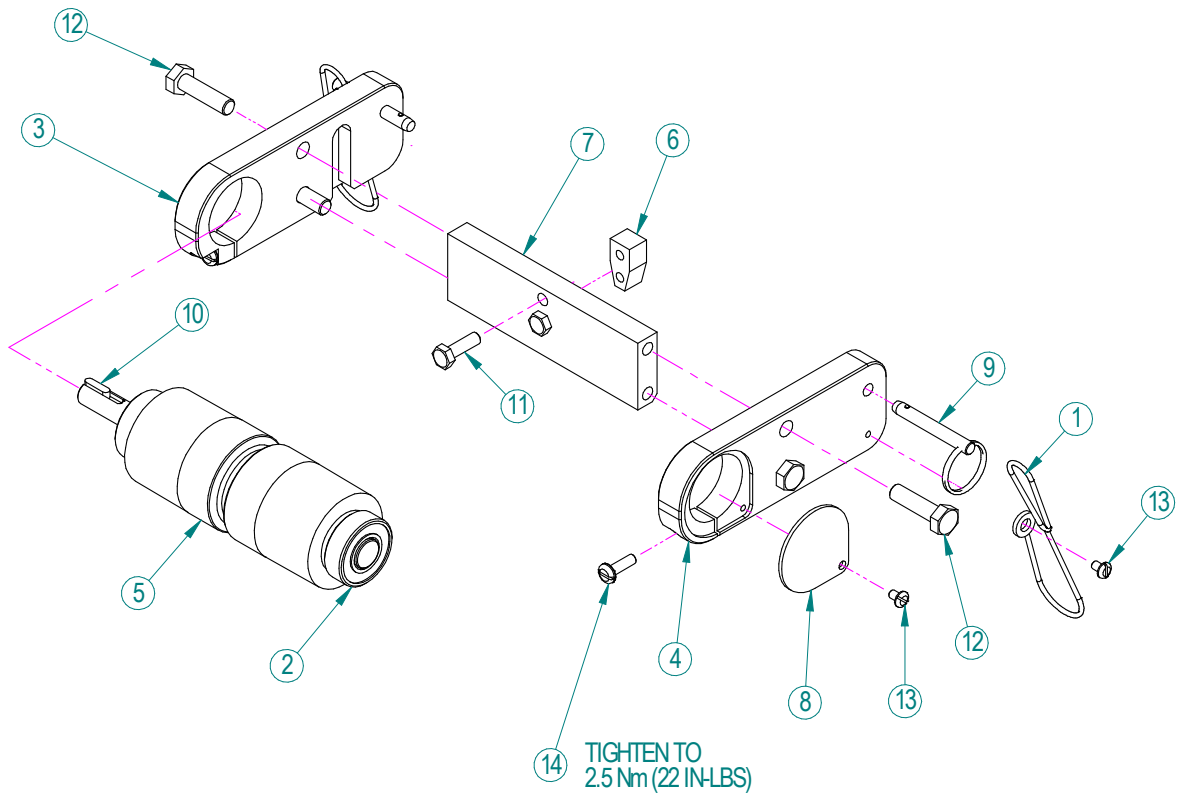

#	Description	Part #
1	NYLON LANYARD	310112-264421-LAYRD
2	BEARING TAIL STAINLESS STEEL	HEA-0010-00
3	BEARING HOUSING DRIVE LH	HEA-0090-LH
4	BEARING HOUSING DRIVE RH	HEA-0090-RH
5	PULLEY - DRIVER	HEA-0140-WW
6	DRIVER CENTER ALIGNMENT BLOCK	HEA-2000-00
7	SPACER - DRIVER	HEA-2003-WW
8	BEARING COVER	HEA-2009-00
9	PULL PIN DRIVE END	HEA-2016-00
10	KEY 4MM SQ X 15MM SS	HEA-2026-00
11	SCREW HEX HEAD CAP M6 X 1 X 20 SS	HHCS-M06X100X020-SS
12	SCREW HEX HEAD CAP M8 X 1.25 X 30 SS	HHCS-M08X125X030-SS
13	SCREW PAN HEAD SLOTTED MACHINE M4 X .7 X 6 SS	PHSMS-M04X070X006-SS
14	SCREW PAN HEAD SLOTTED MACHINE M5 X .8 X 16 SS	PHSMS-M05X080X016-SS

► Right Hand Driver Output

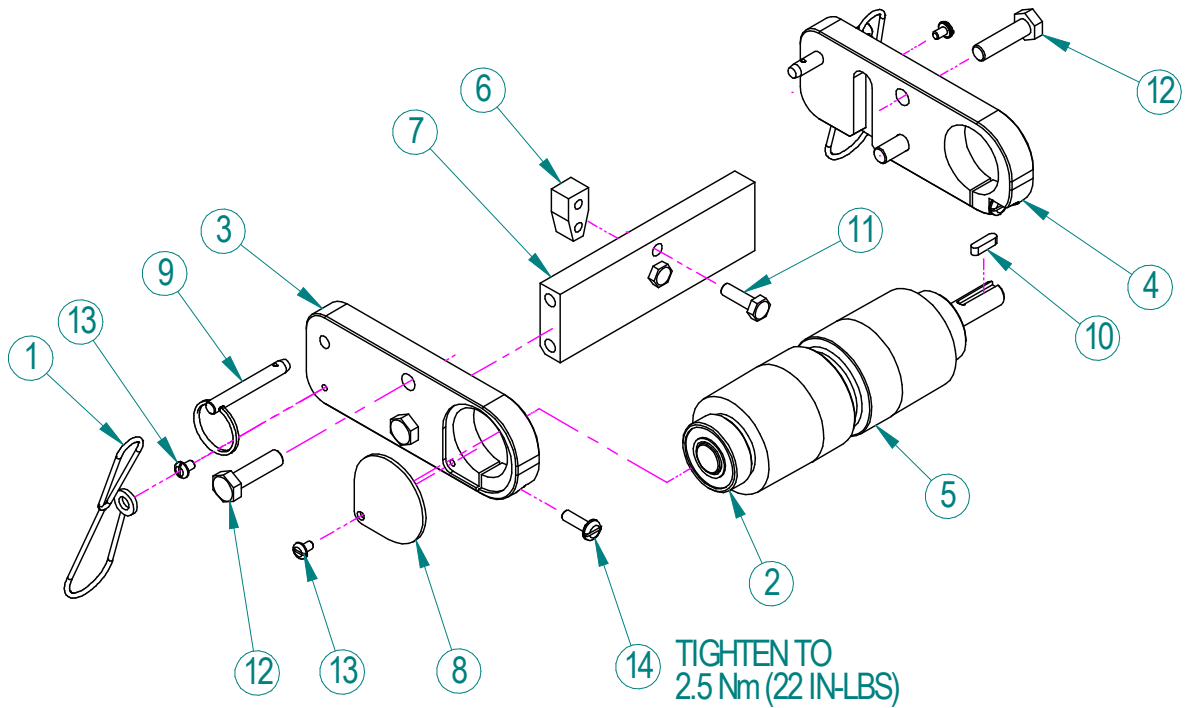

#	Description	Part #
1	NYLON LANYARD	310112-264421-LAYRD
2	BEARING TAIL STAINLESS STEEL	HEA-0010-00
3	BEARING HOUSING DRIVE LH	HEA-0090-LH
4	BEARING HOUSING DRIVE RH	HEA-0090-RH
5	PULLEY - DRIVER	HEA-0140-WW
6	DRIVER CENTER ALIGNMENT BLOCK	HEA-2000-00
7	SPACER - DRIVER	HEA-2003-WW
8	BEARING COVER	HEA-2009-00
9	PULL PIN DRIVE END	HEA-2016-00
10	KEY 4MM SQ X 15MM SS	HEA-2026-00
11	SCREW HEX HEAD CAP M6 X 1 X 20 SS	HHCS-M06X100X020-SS
12	SCREW HEX HEAD CAP M8 X 1.25 X 30 SS	HHCS-M08X125X030-SS
13	SCREW PAN HEAD SLOTTED MACHINE M4 X .7 X 6 SS	PHSMS-M04X070X006-SS
14	SCREW PAN HEAD SLOTTED MACHINE M5 X .8 X 16 SS	PHSMS-M05X080X016-SS

► Flip Up Tail

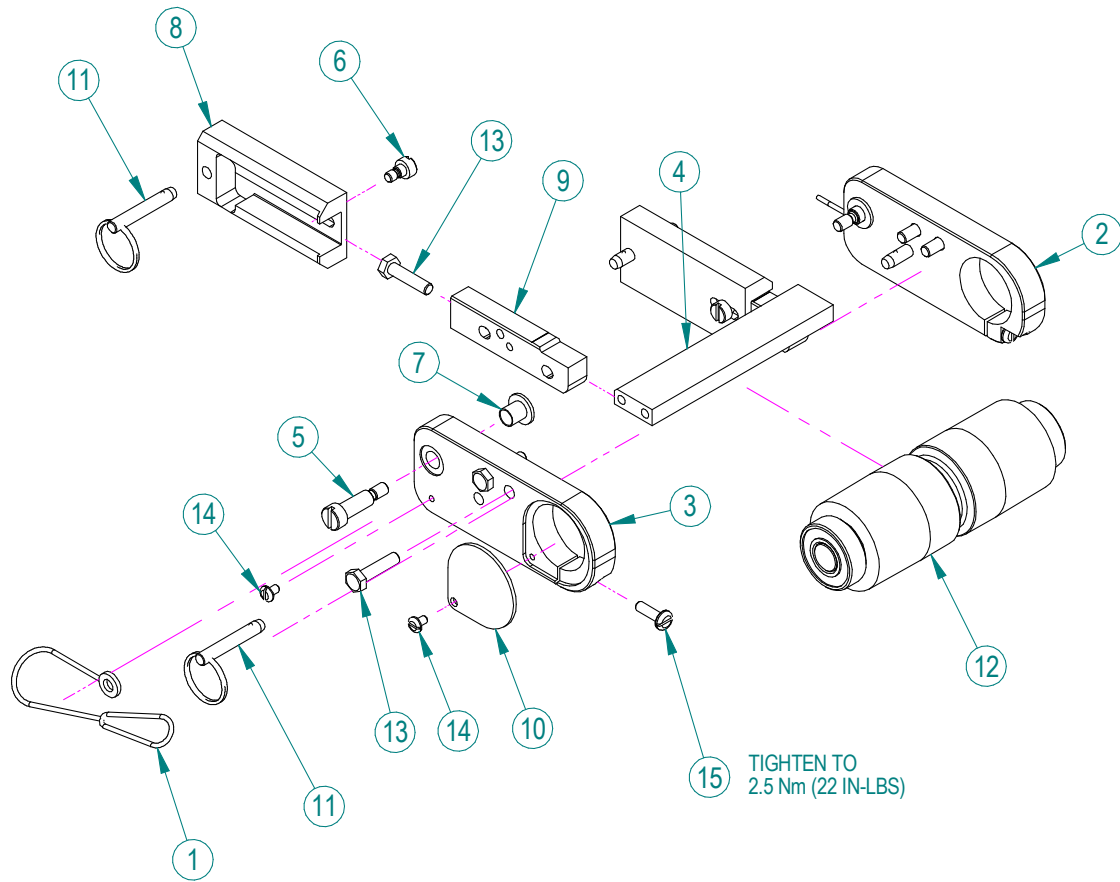

#	Description	Part #
1	NYLON LANYARD	310112-264421-LAYRD
2	BEARING HOUSING TAIL LH	HEA-0092-LH
3	BEARING HOUSING TAIL RH	HEA-0092-RH
4	TAIL SPACER	HEA-0139-WW
5	SCREW SHOULDER 8 DIA X 20 SLOTTED M6	HEA-2004-00
6	SCREW SHOULDER 6 DIA X 4 SLOTTED M5	HEA-2005-00
7	BUSHING FLANGED NYLON	HEA-2006-00
8	TAIL ANCHOR	HEA-2007-00
9	SLIDER TAIL END	HEA-2008-00
10	BEARING COVER	HEA-2009-00
11	PULL PIN DRIVE END	HEA-2016-00
12	ASSY TAIL PULLEY WITH BEARINGS	HEA-2501-WW
13	SCREW HEX HEAD CAP M6 X 1 X 25 SS	HHCS-M06X100X025-SS
14	SCREW PAN HEAD SLOTTED MACHINE M4 X .7 X 6 SS	PHSMS-M04X070X006-SS
15	SCREW PAN HEAD SLOTTED MACHINE M5 X .8 X 16 SS	PHSMS-M05X080X016-SS

► Underside Idler

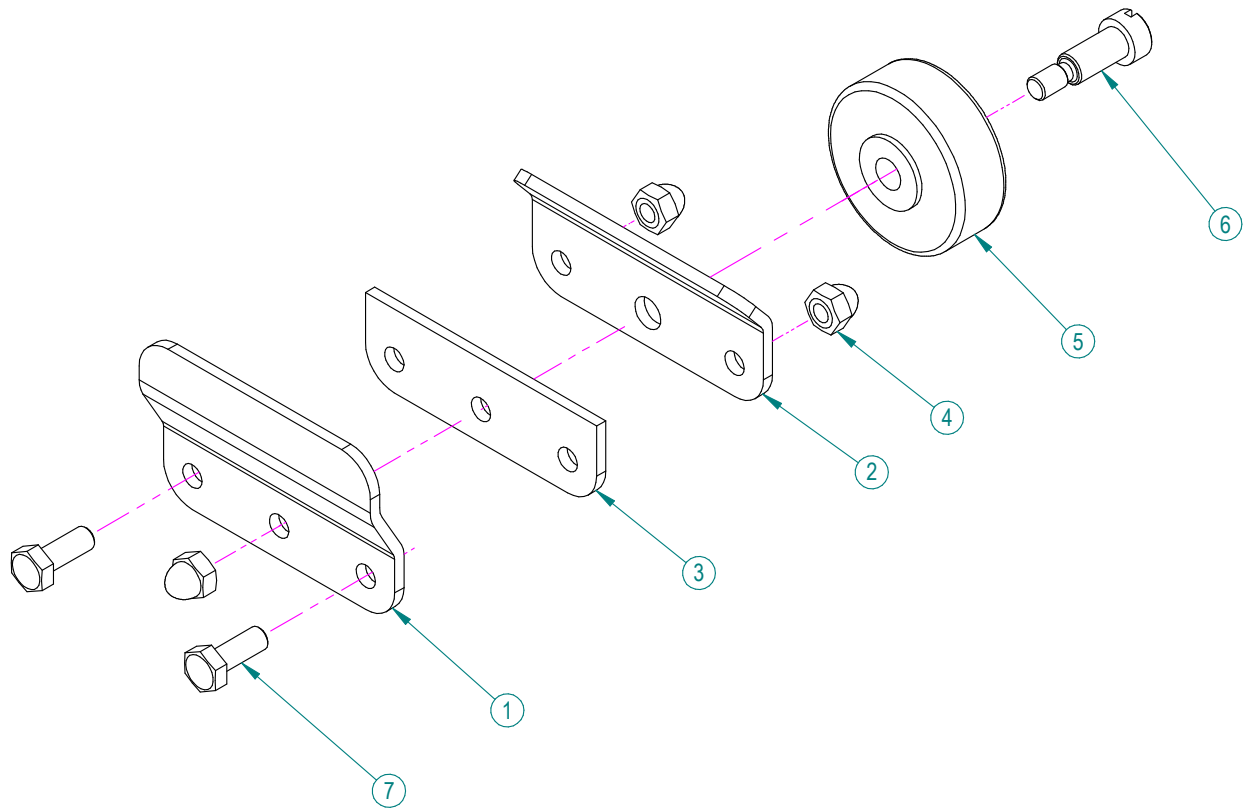

#	Description	Part #
1	IDLER MOUNT - OUTER JAW	HE1-2044-00
2	IDLER MOUNT - INNER JAW	HE1-2045-00
3	IDLER MOUNT - SPACER	HE1-2046-00
4	ACORN NUT STAINLESS STEEL M6	HEA-2014-00
5	IDLER - ROLLER	HEA-2047-00
6	SCREW SHOULDER 8 DIA X 16 SLOTTED M6	HEA-2048-00
7	SCREW HEX HEAD CAP M6 X 1 X 16 SS	HHCS-M06X100X016-SS

► Drive Pulley and Tail Pulley

@ - Part Not Sold Separately

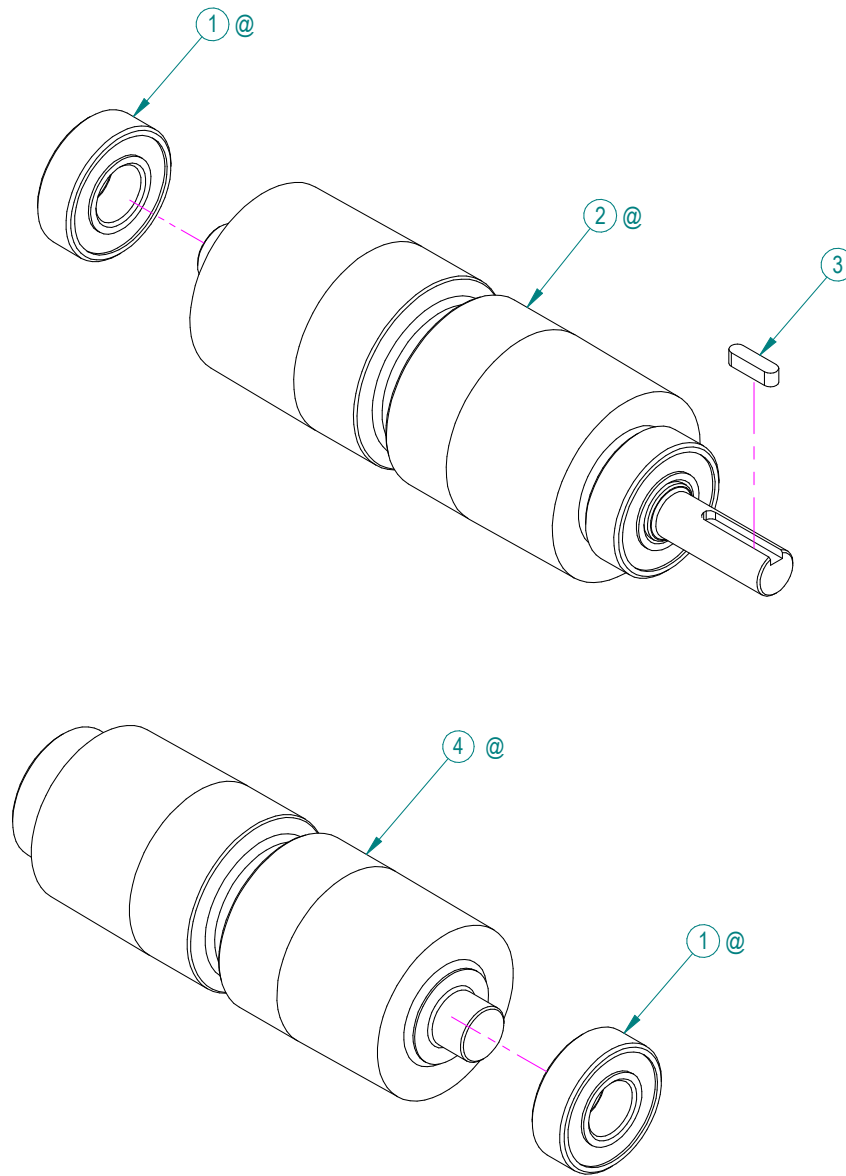

#	Description	Part #
1	BEARING TAIL STAINLESS STEEL	HEA-0010-00
2	PULLEY - DRIVER	HEA-0140-WW
3	KEY 4MM SQ X 15MM SS	HEA-2026-00
4	PULLEY - TAIL	HEA-0113-WW

QC Conveyors warrants that our conveyors are free from defects in materials and workmanship and fit for the ordinary purposes for which such goods are used, under normal installation, use and service for ten (10) years* from date of purchase or 21,000 hours* of running use, whichever is sooner. QC Conveyors will replace any defective part within the warranty period, without charge, provided:

- » The Purchaser gives QC Conveyors prompt written notice of the defect, including the date of purchase and original purchase order number.
- » The Purchaser will then be given a return goods authorization number (RGA#) which must be displayed on all labels and packing slips returned with merchandise. (See Return Policy section)
- » The Purchaser pays for delivery of the defective part to QC Conveyors for inspection and verification of the defect.
- » The Purchaser shall pay any costs of installing the replacement part.

This warranty is limited to the replacement of defective parts. **QC Conveyors WILL NOT BE LIABLE FOR ANY DAMAGES CAUSED BY ANY DEFECT IN THIS UNIT.** This warranty shall not apply if any failure of this unit or its parts is caused by unreasonable use, lack of maintenance, improper maintenance and/or repairs, incorrect adjustments, exposure to corrosive or abrasive material, damage causing moisture, or any modification or alteration affecting the operation of the unit which is not authorized by QC Conveyors in writing. This warranty shall not apply to the following items that are covered by their manufacturer's warranty, subject to any limitation contained in those warranties.

- » Bearings
- » Motors
- » Reducers
- » Controllers
- » Casters
- » Belts (Unless otherwise agreed to in writing)

CAUTION: Any attempt to repair such items may actually void the manufacturer's warranty. Any description of this unit is only to identify it and is not a warranty that the unit fits the description. Any warranties implied by law are limited in duration to the ten (10) year term of this warranty. EXCEPT AS SET FORTH HEREIN, QC Conveyors MAKES NO OTHER WARRANTIES, WHETHER EXPRESS, IMPLIED, OR STATUTORY, INCLUDING MERCHANTABILITY FOR FITNESS OR ANY PARTICULAR PURPOSE.

*Warranty is five years/10,500 hours without registration at qcconveyors.com/serial.

▷ Lost or Damaged Goods

Shipments should be inspected immediately upon receipt for lost or damaged goods. Any loss or damage should be noted on the carriers receipt (or bill of lading) at the time of acceptance. If items are perceived to be lost or damaged after the shipment has been accepted, it becomes more difficult to file a claim with the carrier if the receipt does not indicate such loss or damage. Do not, at any time, request the carrier to return any items or shipment to QC Conveyors without previous authorization from our company for such a return. Please notify QC Conveyors as soon as any loss or damage is discovered and request the department that handles the lost or damaged goods. You will need to know a complete description of all lost or damaged items. If replacement items are needed, a purchase order made out to QC Conveyors will need to be supplied. QC Conveyors will then contact the carrier's local agent and request that an inspection of the items be performed. This is absolutely necessary. Unless an inspection is performed, the carrier will not entertain any claim for loss or damage. After the inspection has been completed, the carrier will notify QC Conveyors. If the carrier takes responsibility for the claim, a credit will be issued to you for the replacement item(s), including freight charges from QC Conveyors, where applicable. If the carrier does not take responsibility for the claim, a representative of QC Conveyors will contact you.

▷ Limited Restocking Policy – Products Available for Limited Restocking

We take great pride in our intentionally engineered conveyor systems built for use by you and your customers. Please review the below chart of products available for limited restocking and then review the appropriate policy that applies to the issue at hand.

Product Line	Restock Fee/Cancellation Charge
Automation Series: AS40, AS40-CD, AS40-Z, CB80 Conveyor Systems/Parts	25% Restock Fee/Cancellation Charge
Industrial Series: IS125, IS125-FT, IS175-ID, IS300, IS400 Conveyor Systems/Parts	25% Restock Fee/Cancellation Charge
HydroClean Series: HC200 Conveyor Systems/Parts	30% Restock Fee/Cancellation Charge
Flextrac Series: Alpine, Modular Plastic Chain, Gripper Elevator (Wedge) Conveyor Systems/Parts	50% Restock Fee/Cancellation Charge
Custom OEM Product Lines	25% Restock Fee/Cancellation Charge
PF Series	20% Restock Fee/Cancellation Charge
Custom Engineered/Special Conveyors, Belts or Parts; Discontinued Product Lines	Non-Returnable

If it becomes necessary to cancel or revise an order prior to the order being shipped, QC Conveyors reserves the right to evaluate each order independently prior to authorizing cancellation/revision; restocking / cancellation fees may apply. A restocking charge will be invoiced if an order has been assembled prior to its cancellation or revision. We will not restock custom components (items that are not stocked at QC Conveyors) and those items will be invoiced to the purchaser at list price. If the order contains other-than-stock items, an evaluation will be made based on the status of the order. Additional charges may be included in addition to the restocking fee, if any of the following conditions are met:

- (1) The order contains any items that are considered to be non-stock items and these items have already been produced or are in process by QC Conveyors or one of its suppliers.
- (2) The order contains any items that require special handling or assembly and these processes have been completed.

Limited Restocking Policy ◀

Restocking must meet the following criteria prior to an RGA (Restock Goods Authorization) number being issued:

- (1) Items must be eligible for restock.
- (2) Items must have been purchased within 60 Days (based on invoice date).
- (3) Items must be unopened, undamaged and in resalable condition.

RGA Process – Restocking Goods Authorization ◀

Contact QC Conveyors — Email customerservice@qcconveyors.com or call Customer Service at 513-753-6000

Information Needed for RGA

- (1) Name of Purchaser (Company QC Conveyors invoiced, may be the distributor, if applicable)
- (2) Name of the Customer and/or end user of the item(s).
- (3) Invoice Number - Include any/all purchase order numbers related to the item(s) in question.
- (4) Contact Information - Phone numbers and names of contacts involved.
- (5) Item Number(s) & Quantities - Complete part numbers /quantities of all items involved in the RGA.
- (6) Reason - Complete description as to the reason for the return and the actions that need to be taken.
If the item is to be replaced, a new purchase order number must be supplied by the Purchaser along with complete shipping and billing instructions. These replacements will be treated as separate orders by QC Conveyors and evaluated for possible credit only after returned items are received and evaluated.

Process Once RGA is Approved

- (1) **QC Conveyors Will Email RGA Number** — Once all the above information is provided, we will begin processing your RGA. Once authorization has been approved, you will be emailed the RGA number to use when returning the item(s). RGA numbers will not be given verbally over the phone.
- (2) **Items Must Be Received 30 Days from RGA Issue Date** — Upon receipt of your RGA number, you are required to return the item(s) within 30 days of receipt of RGA number email. After 30 days, the Return Authorization will be void if item(s) are not received by QC Conveyors. All shipping charges and freight insurance charges of restocked goods will be the responsibility of the Purchaser.
- (3) **Returned Items Must Have RGA Number Listed on Packaging** — The RGA number must be clearly marked on the outside of all packages and noted on any paperwork, packing slips, or delivery receipts. If there is no RGA number visible on the package, the package may be refused and sent back at the Purchaser's expense. Parts received in damaged condition due to inadequate packaging are not eligible for credit or warranty consideration.
- (4) **QC Conveyors Will Evaluate RGA and Credit If Applicable** — After receipt of returned goods, QC Conveyors will evaluate the item(s) for credit and take the appropriate action. Items outside of Warranty Issues must be on the Limited Restocking List, must be returned in new, undamaged, resalable condition and must be received within 30 days of RGA Number being assigned. Credit will be issued to the purchaser less restocking fee and any additional fees (evaluation, disassembly, cleaning, disposal, and reissuing of components into inventory). Please allow 30 days for credits to be issued. Full purchase credit will only be issued for defective or damaged initial shipping issues.

»» qcconveyors.com/serial

Manuals, Videos, Replacement Parts

» Register today to double your warranty to 10 Years

QC Conveyors come standard with a 5 Year manufacturer's warranty, but if you register online we'll double that to 10 Years, giving you the longest warranty in the conveyor industry.



Register today at qcconveyors.com/serial!

While You're There, You'll Have Access to

- » All the installation and maintenance manuals for your product
- » Product-specific videos to guide you through routine maintenance tasks
- » A complete list of replacement parts along with the original bill of materials and exploded views to help you find exactly the right part
- » Easy replacement part quoting



Registration also entitles you to all the benefits of our Conveyor Configurator, where you can configure and quote conveyor systems with help from our engineering-based configuration tools to ensure your conveyor and components will work together perfectly in your application.

Service Record

Date	Service Performed

▶ Serial Number

▶ Date of Installation

Service Record

Date	Service Performed

▶ Serial Number

▶ Date of Installation
