



# PF52 Dual Drive Control Panel

COMPATIBLE WITH GFCI CIRCUIT BREAKER

\*Intended for use in kit



## Specifications

- » UL Listed
- » IP66 protected enclosure with cord strain reliefs
- » Dual 200 watt controllers for brushless DC gearmotors
- » 230 volt, Single Phase 50 or 60 Hz power input, 10 amp max
- » Includes internal circuit breaker
- » M12 receptacle for connection to emergency stop circuit with illuminated button (supplied by KES)
- » Relays to halt conveyors when emergency stop is pressed or guard is removed from either conveyor, condition indicated by LED lights on the relays
- » Single 3 position start/stop/reset switch for both conveyors
- » Speeds are preset to 1800 rpm (Conveyor 1) and 2400 rpm (Conveyor 2)
- » Color-coded modular connectors on 1m long cables located outside enclosure



## Drawings

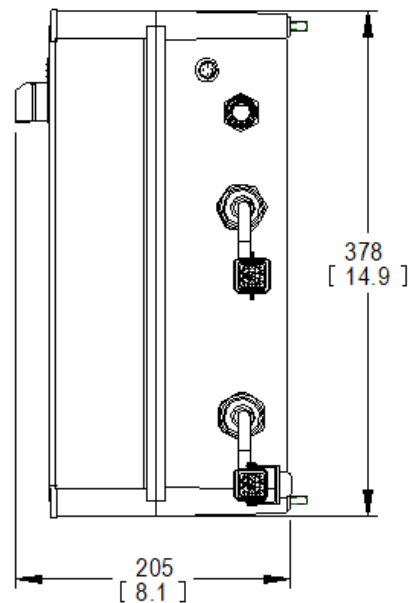
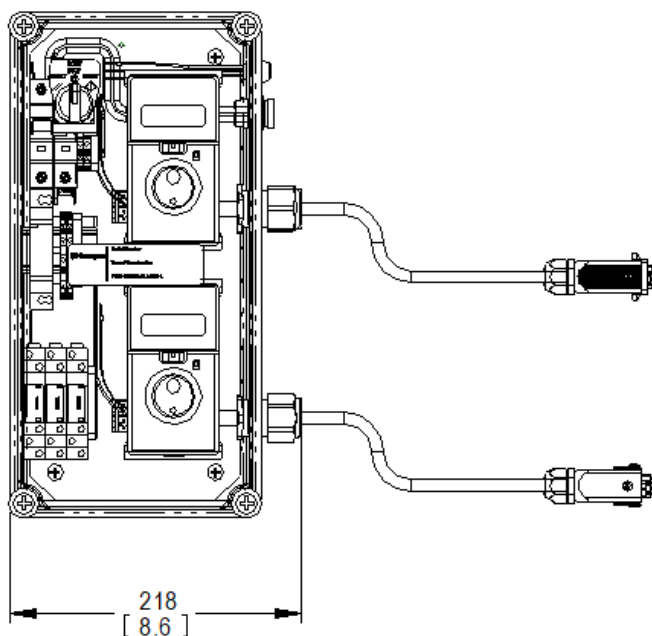

## Part Numbers

PF52-EPANEL-UL1-230-1

QC Specification  
Number

Describer

Input Voltage  
and Phase